

C41V Probe

INSTRUCTION MANUAL
--- For USA ---



Tokyo , Japan

Q1E-EP1438-2









©Hitachi, Ltd. 2013,2016. All rights reserved.

CONTENTS

1.	Foreword.....	1
2.	General caution.....	2
3.	General.....	6
4.	Probe Components List.....	7
5.	Accessories (Option).....	7
5.1	Puncture guide bracket EZU-PA3V(Disposable).....	7
6.	External View.....	8
7.	Cleaning and sterilization of the Probe C41V.....	9
7.1	Levels of Disinfection Requirement.....	9
7.2	Reprocessing Procedure.....	10
7.3	Cleaning Process(C41V).....	11
7.4	Liquid Chemical Sterilization Process(C41V).....	13
7.5	EtO Sterilization Process(C41V).....	14
7.6	Plasma Sterilization Process(C41V).....	15
8.	Cleaning and sterilization of the Puncture Adapter(EZU-PA3V).....	16
8.1	Cleaning Process(EZU-PA3V).....	16
8.2	Liquid Chemical Sterilization Process(EZU-PA3V).....	17
8.3	Autoclave Sterilization Process(EZU-PA3V).....	18
9.	Operating Procedure.....	20
9.1	Connection and Settings.....	20
9.2	Use of Puncture Adapter(EZU-PA3V).....	22
9.3	Display of Needle Guide Line.....	23
9.4	Diagnosis.....	24
9.5	Care after use.....	24
10.	Maintenance and Safety Inspection.....	25
10.1	Probe Care.....	25
10.2	Daily Inspection.....	25
11.	Specifications.....	26
12.	Supplier's List.....	27
13.	Disposal of the probe.....	27

Definition of symbol

The following symbol is also used for HITACHI Ultrasound Probes.

Location	Symbol	Definition
Probe connector		This instrument complies with Directive 93/42/EEC relating to Medical Device and Directive 2011/65/EU relating to RoHS
Probe connector	IPX7	IPX7 mark See section 6.
Probe connector		Type BF APPLIED PART
Probe connector		General warning sign
Probe connector		Warning; dangerous voltage
Probe connector		Caution; Biohazard
Probe connector		Follow the instruction manual to operate this instrument. If not avoided, may result in injury, property damage, or the equipment trouble.
Probe connector		STERRAD sterilization compatibility mark
Probe connector		Do not waste the instrument as general waste. Comply with a local regulation.
Probe connector	Rx Only	By prescription only. U.S. Federal Law restricts this device to sale on order of a physician only.

1. Foreword

Before using the probe, carefully read this instruction manual for correct and safe handling of the probe as well as for making the most of the performances of the probe and the ultrasound scanner with which the probe is to be used.

Notes to Users

To ensure safe operation, it is essential that you fully understand the function, operating and maintenance instructions by thoroughly reading and understanding this manual and the manuals that accompany probes and accessories before operating this equipment, paying particular attention to all warnings, cautions, and notes incorporated herein. Please contact a service support if you have any questions concerning the operation of equipment.

The following conventions are used throughout the manual to denote information of special emphasis:

- WARNING:** "Warning" is used to indicate the presence of a hazard which can cause severe personal injury, death, or substantial property damage if the warning is ignored.
- CAUTION:** "Caution" is used to indicate the presence of a hazard which will or can cause minor personal injury or property damage if the caution is ignored.
- NOTE:** "Note" is used to notify people of installation, operation, or maintenance information which is important, but not hazard related.

2. General caution

For safe use of the ultrasound scanner and probe, it is advisable to strictly observe the following:

〈CAUTION〉

- 1) Federal law restricts this device to use by or on the order of a physician.
- 2) Be sure to read and observe the "General Cautions in Operation" stated in the operation manual for the ultrasound scanner with which the probe is to be used.
- 3) The probe and ultrasound scanner with which it is used should never be operated in an environment at a higher or lower temperature, under a higher or lower pressure and a higher humidity, than the specified operating ambient conditions. (Also see the paragraph "11. Specifications".)
- 4) Never try to remodel the probe and ultrasound scanner; if they are remodeled, a fault will possibly be caused.
- 5) Do not use chemicals or organic solvents such as thinner for wiping the probe. (See the paragraph "10.1 Probe Care".)
- 6) Do not hit or drop the probe because the inside of the probe head is easily broken by mechanical shocks.
- 7) Keep the probe head off substances containing fatty acid (hydrocarbon of methane series, paraffin). Because it soaks into the inside of the probe head through the surface of the probe head and cause a fault.
- 8) If the ultrasound scanner and probe malfunction, contact our service personnel.
- 9) The use of a sterile probe sheath is recommended with this probe.
- 10) Use only sterilized acoustic gel during examinations in which sterile techniques are used.
- 11) Since the acoustic jelly accessory to the ultrasound scanner is not a sterilized one, so never use it directly on biopsy use.

NOTE: The warranty period of the probes is one year from their delivery to the user. If they become faulty within this period and it is evident that Hitachi is responsible for the fault, they will be repaired or replaced with normal ones free of charge.

NOTE: This warranty does not cover accidental damage on your site or improper handling, such as wear, extreme temperature, damages caused by chemical acids and solvents.

⟨ WARNING ⟩

Before examination of patient, be sure to connect the probe with the ultrasound scanner and to check for normal operation of the system.

If the needle guide line is used, especially check that the needle line is correctly displayed. Refer to the instruction manual for the ultrasound scanner with which the probe to be used for display procedure of the needle guide line.

If it is not displayed correctly, contact service personnel of our authorized agent.

⟨ WARNING ⟩

Because of reports of severe allergic reactions to medical devices containing latex (natural rubber), the FDA is now advising health-care professionals to screen their latex-sensitive patients, and be prepared to treat allergic reactions promptly. Please read and become familiar with the FDA Medical Alert report of March 29, 1991, titled, "Allergic Reactions to Latex-Containing Medical Devices", reprinted on the following pages.

In certain applications, the use of a protective sheath is recommended. Because of the possibility of latex-sensitive patients, Hitachi and HAMA are now recommending the use of non-latex covers. Specifically, we are recommending that the end user utilize the following devices:

Device: CIVCO PRO/Covers™

Manufacturer: CIVCO Medical Instruments Company, Inc.

We recommend that the end user contact CIVCO directly for obtaining sizing and pricing information, samples, and local distribution information.



Medical Alert

March 29, 1991
MDA91-1

Lenore Gelb
(301) 443-3220

Allergic Reactions to Latex-Containing Medical Devices

Because of reports of severe allergic reactions to medical devices containing latex (natural rubber), FDA is advising health-care professionals to identify their latex-sensitive patients and be prepared to treat allergic reactions promptly. Patient reactions to latex have ranged from contact urticaria to systemic anaphylaxis. Latex is a component of many medical devices, including surgical and examination gloves, catheters, intubation tubes, anesthesia masks, and dental dams.

Reports to FDA of allergic reactions to latex-containing medical devices have increased lately. One brand of latex-cuffed enema tips was recently recalled after several patients died as a result of anaphylactoid reactions during barium enema procedures. More reports of latex sensitivity have also been found in the medical literature. Repeated exposure to latex both in medical devices and in other consumer products may be part of the reason that the prevalence of latex sensitivity appears to be increasing. For example, it has been reported that 6% to 7% of surgical personnel and 18% to 40% of spina bifida patients are latex-sensitive.

Proteins in the latex itself appear to be the primary source of the allergic reactions. Although it is not now known how much protein is likely to cause severe reactions, FDA is working with manufacturers of latex-containing medical devices to make protein levels in their products as low as possible.



FOOD AND DRUG ADMINISTRATION
U.S. Department of Health and Human Services
Public Health Service
5600 Fishers Lane, Rockville, Md. 20857

FDA's recommendations to health professionals in regard to this problem are:

- When taking general histories of all patients, include questions about latex sensitivity. For surgical and radiology patients, spina bifida patients, and health-care workers, this recommendation is especially important. Questions about itching, rash or wheezing after wearing latex gloves or inflating a toy balloon may be useful. Patients with positive histories should have their charts flagged.
- If latex sensitivity is suspected, consider using devices made with alternative materials, such as plastic. For example, a health professional could wear a non-latex glove over the latex glove if the patient is sensitive. If both the health professional and patient are sensitive, a latex middle glove could be used. (Latex gloves labeled "hypoallergenic" may not always prevent adverse reactions.)
- Whenever latex-containing medical devices are used, especially when the latex comes in contact with mucous membranes, be alert to the possibility of an allergic reaction.
- If an allergic reaction does occur and latex is suspected, advise the patient of a possible latex sensitivity and consider an immunologic evaluation.
- Advise patients to tell health professionals and emergency personnel about any known latex sensitivity before undergoing medical procedures. Consider advising patients with severe latex sensitivity to wear a medical identification bracelet.

FDA is asking health professionals to report incidents of adverse reactions to latex or other materials used in medical devices. (See the October 1990 *FDA Drug Bulletin*.) To report an incident, call the FDA Problem Reporting Program, operated through the U.S. Pharmacopeia toll-free number: 800-638-6725. (In Maryland, call collect 301-881-0256.) For further information on the clinical aspects of latex sensitivity, call Claudia Gaffey, M.D., Office of Health Affairs, Center for Devices and Radiological Health, at (301) 427-1060.

For a single copy of a reference list on latex sensitivity, write to: LATEX, FDA, HFZ-220, Rockville, MD 20857.

☆☆☆

3. General

C41V Probe is of convex array electronic scanning type. This is designed for use as connected with Hitachi Ultrasound scanner.

Clinical Intended Use

Please refer to the Instruction Manual (Supplement - Safety and Effectiveness) of the scanner with which this probe is combined.

NOTE: Do not use this probe for a purpose out of the specified intended use, and the intended use of this probe is limited each device. Please contact your local Hitachi representative with any question on this probe availabilities and intended uses.

Acoustic output

Please refer to the Instruction Manual (Supplement - Safety and Effectiveness) of the scanner with which this probe is combined.

Clinical Measurement Accuracy

In case of using measurement function with this probe, please refer to the Instruction Manual (Supplement - Safety and Effectiveness) of the scanner with this probe is combined with regard to the clinical measurement accuracy.

4. Probe Components List

The components list of C41V is given in Table.1.

Table.1 Probe component list

Component		Note
1	C41V Probe	1 piece
2	Instruction manual	1 copy
3	Shipping & storage box	1 set

5. Accessories (Option)

5.1 Puncture Adapter EZU-PA3V(Disposable)

Attachment for ultrasound guided transrectal biopsy and aspiration. Available needed size 16 to 19G. Application requires special care.

The components list of the EZU-PA3V is given in Table.2.

Table.2 Needle guide bracket component list

Component		Note
1	Puncture Adapter (16G,17G,18G,19G are compatible)	3 pieces

NOTE: If you need Puncture Adapter, please contact your local HITACHI distributor.

6. External View

The external view of C41V is given in Fig.1.

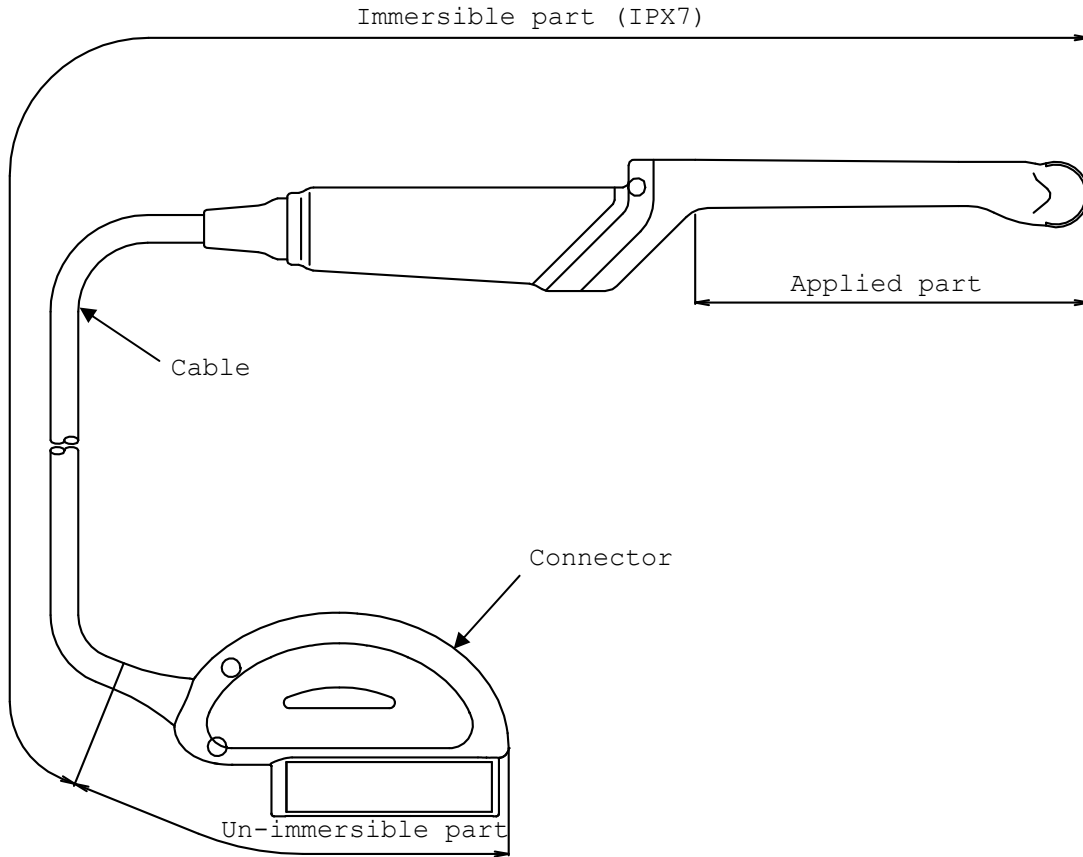

- Immersible part: This part can be immersed in sterilant/disinfectant solution and also can be cleaned by water.
- Un-immersible part: This part should not be immersed in sterilant/disinfectant solution and also can not be cleaned by water.

Fig.1 External view

7. Cleaning and sterilization of the Probe (C41V)

The probe is not sterilized, but must be sterilized before initial use, and after each every subsequent use, the probe must be sterilized, following the directions given below and working in accordance with standard hospital practice. (For reference, consult "Good Hospital Practice: Handling and Biological Decontamination of Reusable Medical Devices: ANSI/AAMI ST35-1991", published by the Association for the Advancement of Medical Instrumentation.)

7.1 Levels of Disinfection Requirement

To choose an appropriate sterilant/disinfectant, the user must determine the required level of disinfection, based on the following classification (See Table.3) and the regulation of each country.

Table.3 Levels of Disinfection Requirements

Classification	Definition	Levels of disinfection
Critical	Device directly contacts tissue (Intraoperative applications)	Sterilization
Semi-critical	Device contacts mucous membranes (Intracavity applications)	Sterilization or minimally High
Non-critical	Device contacts intact skin	Intermediate or low

7.2 Reprocessing Procedure

After each use of the probe, the reprocessing procedure including cleaning and sterilization must be performed immediately. A flow diagram showing the steps of the reprocessing procedure is given in Fig.2. The reprocessing procedure must be performed even after the probe was used with a probe sheath.

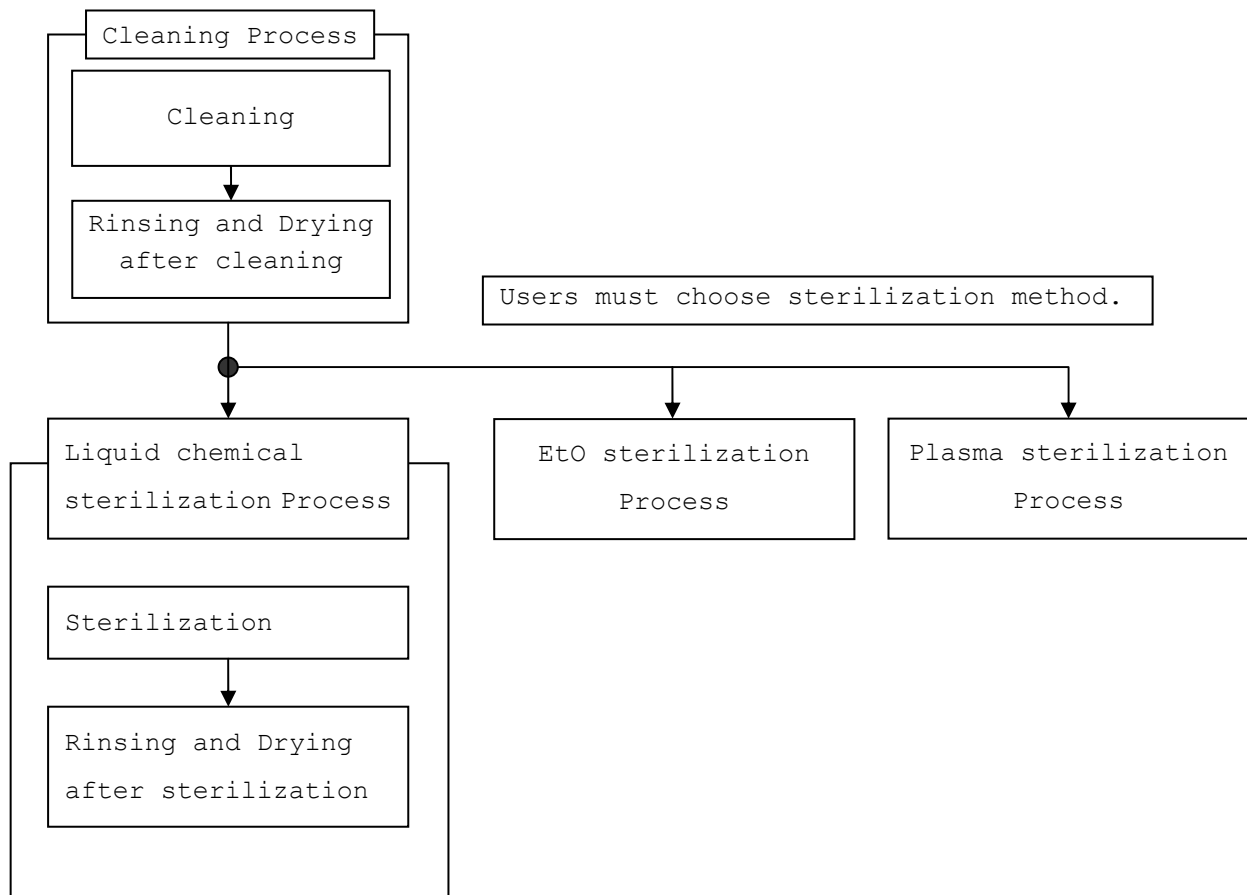

Fig.2 Reprocessing Procedure

⚠ WARNING ⚠

Do not sterilize the probe by Autoclave.
Autoclave sterilization causes the probe to malfunction.

7.3 Cleaning Process (C41V)

Prior to liquid chemical sterilization or EtO sterilization /Plasma sterilization process, the probe must be cleaned.

7.3.1 Removal of the puncture adapter (EZU-PA3V)

Remove the puncture adapter from the probe as shown (See Fig.3)

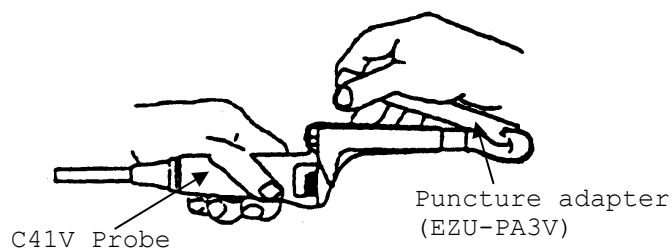

Fig.3 Removal of the puncture adapter

7.3.2 Cleaning

Immerse the probe in an enzymatic detergent (Enzol[®]) solution (as shown in Fig. 4) for more than 30 minutes or until the visible residue is removed.

If needed, scrub the probe using a soft sponge, gauze, or cloth to remove visible residue from the surface of the probe.

< WARNING >

Follow the instructions of the enzymatic detergent manufacturer regarding recommended dilution, temperature and soak time. Using insufficiently diluted detergent may damage the probe.

7.3.3 Rinsing and Drying after Cleaning

After cleaning and prior to liquid chemical sterilization, the probe must be thoroughly rinsed with deionized running water or sterile water for more than 10 minutes to remove all residue of the detergent solution (See Fig.5). After rinsing the probe, air-dry it completely.

⟨ WARNING ⟩

Remove all debris and residue of sterilant/detergent solution from the surface of the probe sufficiently.

Debris and residue of sterilant/detergent solution on the surface of the probe may affect patient health.

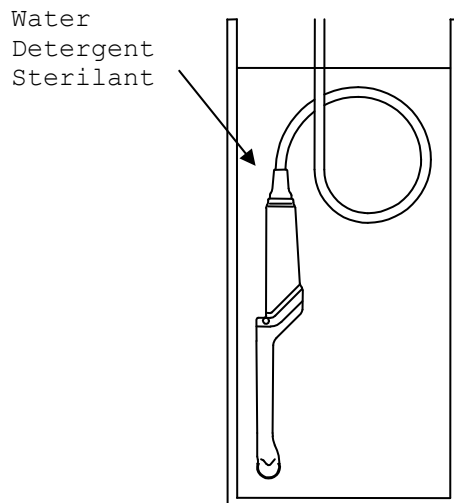

Fig.4 Immersion of the Probe

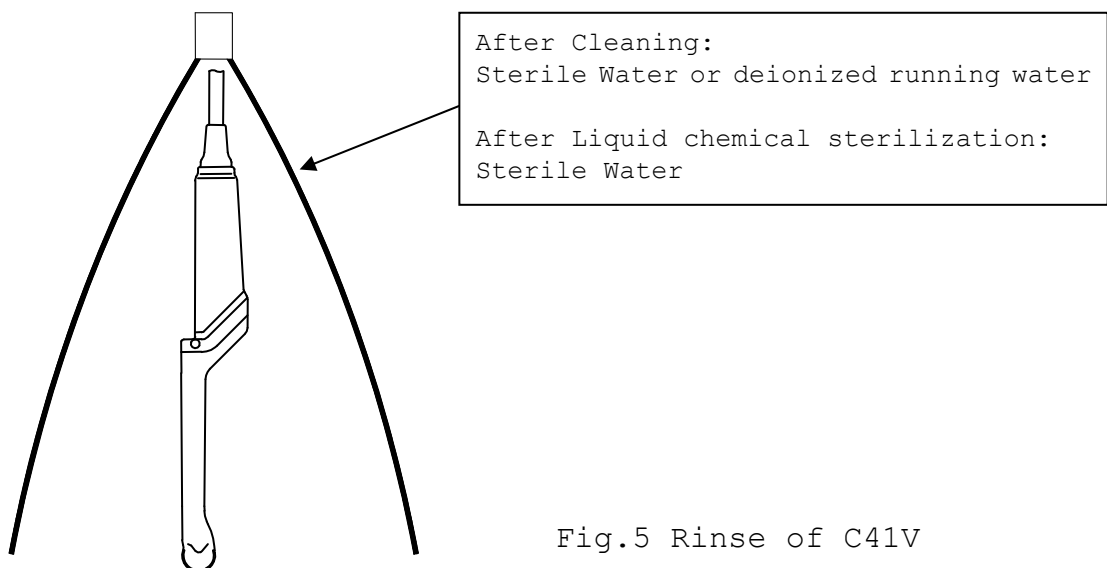

Fig.5 Rinse of C41V

7.4 Liquid Chemical Sterilization Process (C41V)

For sterilization of C41V using liquid chemicals, follow the procedures as indicated in this section. (For reference, consult "Chemical Sterilants and sterilization Methods - A Guide to Selection and Use: AAMI TIR7-113", published by the Association for the Advancement of Medical Instrumentation).

7.4.1 Sterilization

Immerse the probe in a sterilant (Refer to 12. Supplier's List) following the manufacturer's directions regarding preparation and soak time (Fig.4). The contact condition of recommended solutions is given in Table 4.

Table.4 Contact condition of sterilant

Solution	Contact condition	Purpose
Cidex®	10 hours at 25°C	Sterilization
Cidex plus®	10 hours at 20-25°C	Sterilization

<CAUTION>

- (1) Do not mix any solution into a disinfectant unless otherwise indicated by the manufacturer.
- (2) Do not use activated disinfectant solution beyond the expiration date.
- (3) Do not immerse the probe in liquid sterilant/disinfectant more than 15 hours.
- (4) Do not immerse the probe in sterilant/disinfectant solution exceeding 30°C in temperature.

7.4.2 Rinsing and drying

Use sterile technique when removing the probe from the sterilant/disinfectant solution and rinse the probe thoroughly by soaking in sterile water for more than 10 minutes (See Fig.5). After rinsing the probe, air-dry it completely.

〈 WARNING 〉

- (1) Remove all debris and residue of sterilant/disinfectant solution from the surface of the probe sufficiently. Debris and residue of sterilant/disinfectant may affect patient health.
- (2) The probe connector is not waterproof. Do not allow liquid to contact the connector.

7.5 EtO Sterilization Process (C41V)

C41V is compatible with Ethylene Oxide (EtO) Sterilization. This manual does not describe the instruction of EtO sterilizer, therefore, follow the instructions of your sterilizer regarding the operation.

7.5.1 EtO Sterilization

Ensure that the probe is cleaned in accordance with the procedure stated in "7.3 Cleaning Process" before the sterilization. Perform sterilization operations with the condition given in Table 5.

Table.5 EtO Sterilization condition

System	EtO Gas Sterilization Automat, closed system	
Conditions	Gas type:	10%EO/90%HCFC
	Temperature:	max.55°C
	Pressure:	8-200kPa
	Humidity:	50%
	Exposure time:	max.3h
Aeration	Temperature:	max55°C
	Time:	min.18h

7.6 Plasma Sterilization Process (C41V)

C41V is compatible with STERRAD® Plasma Sterilization (STERRAD® 50,100S and 200). This manual does not describe the instructions of STERRAD® system, therefore, follow the instructions of your STERRAD® system regarding the operation.

7.6.1 STERRAD® Sterilization (Johnson & Johnson Product)

Ensure that the probe is cleaned in accordance with the procedure stated in "7.3 Cleaning Process" before the sterilization. Perform sterilization operations by following the instructions of the manufacturer.

〈 WARNING 〉

Confirm the sterilization condition before performing sterilization. The sterilization by other than the specified condition causes the probe to malfunction.

8. Cleaning and sterilization of the Puncture Adapter (EZU-PA3V)

The puncture adapter is not sterilized, but must be sterilized before initial use.

NOTE: The puncture adapter (EZU-PA3V) is disposable. DO NOT reuse.

8.1 Cleaning Process (EZU-PA3V)

8.1.1 Cleaning

Immerse the puncture adapter (EZU-PA3V) in an enzymatic detergent solution. (See Fig.6)

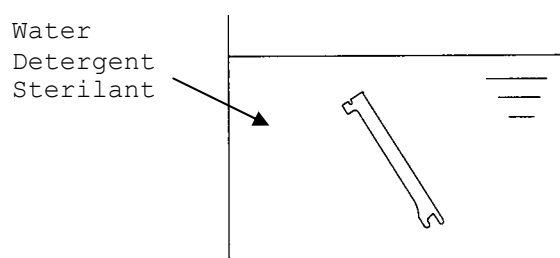

Fig.6

With the puncture adapter EZU-PA3V completely submerged in the detergent solution, insert a biopsy needle of the correct size into the channel, making sure the distal end of the needle passes the entire length of the channel. While being careful to insure that both ends of the channel remain submerged in the detergent solution, withdraw the needle from the channel so as to draw solution into the lumen interior.

Soak the puncture adapter EZU-PA3V in the enzymatic detergent for not less than 30 minutes to remove all visible soil and dried protein.

8.1.2 Rinsing and drying

After cleaning and prior to liquid chemical sterilization, the puncture adapter must be thoroughly rinsed with deionized running water or sterile water for more than 10 minutes to remove all residue of the detergent solution (See Fig.7).

With the puncture adapter completely submerged in deionized running water or sterile water, insert a biopsy needle of the correct size into the channel, making sure the distal end of the needle passes the entire length of the channel. While being careful to insure that both ends of the channel remain submerged, withdraw the needle from the channel.

After all residue of detergent solution has been removed, thoroughly dry the adapter with a soft cloth or towel. Do not use an abrasive sponge.

NOTE: To allow adequate contact of the sterilizing agent with the interior surface of the needle channel in the puncture adapter EZU-PA3V, it is necessary to remove all rinse water from the lumen interior.

After thoroughly drying the exterior of the puncture adapter EZU-PA3V, insert a dry biopsy needle of the correct size into the channel, making sure the distal end of the needle passes the entire length of the channel. Withdraw the needle from the channel to draw air into the lumen interior. As necessary, dry the needle and repeat the process.

8.2 Liquid Chemical Sterilization Process (EZU-PA3V)

8.2.1 Sterilization

Immerse the puncture adapter in a sterilant (Refer to 12. Supplier's List) following the manufacturer's directions regarding preparation and soak time (Fig.6). The contact condition of recommended solutions is given in Table 6.

Table.6 Contact condition of sterilant

Solution	Contact condition	Purpose
Cidex®	10 hours at 25°C	Sterilization
Cidex plus®	10 hours at 20-25°C	Sterilization

⟨CAUTION⟩

- (1) Do not mix any solution into a sterilant/disinfectant unless otherwise indicated by the manufacturer.
- (2) Do not use activated sterilant/disinfectant solution beyond the expiration date.

NOTE: Prior to the start of the soak cycle, it is necessary to remove all air from the biopsy channel in the puncture adapter to allow contact of the lumen interior with the sterilant solution.

With the puncture adapter EZU-PA3V completely submerged in sterilant solution, insert a biopsy needle of the correct size into the channel, making sure the distal end of the needle passes the entire length of the channel. While being careful to insure that both ends of the channel remain submerged in sterilant solution, withdraw the needle from the channel.

8.2.2 Rinsing and Drying after sterilization

Use sterile technique when removing the puncture adapter from the sterilant solution and rinse the puncture adapter thoroughly by soaking in sterile water. (See Fig. 7)

The puncture adapter must be thoroughly rinsed with sterile water to remove all residue of the sterilant solution. After rinsing the puncture adapter, air-dry it completely.

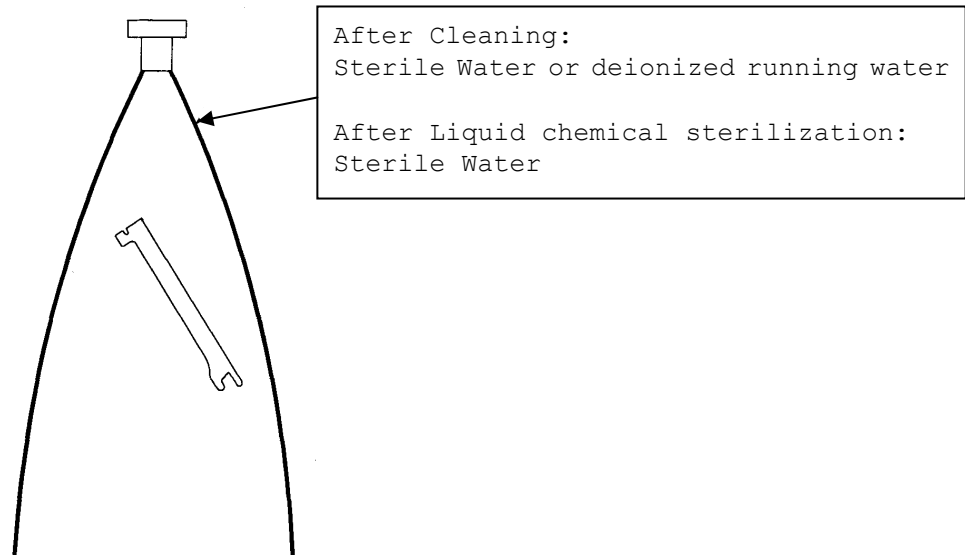

Fig.7

With the puncture adapter EZU-PA3V completely submerged in sterile water, insert a sterile biopsy needle of the correct size into the channel, making sure the distal end of the needle passes the entire length of the channel. While being careful to insure that both ends of the channel remain submerged, withdraw the needle from the channel.

Repeat as necessary to insure that all residue of the sterilant solution is flushed from the channel interior. After all residue of sterilant solution has been removed, thoroughly dry the puncture adapter.

8.3 Autoclave Sterilization Process (EZU-PA3V)

Use autoclave under following conditions.

- a. Temperature :132 - 148°C
- b. Time :greater than 10 minutes

〈CAUTION〉

Autoclave temperature above 150°C (320°F) will damage the puncture adapter.

9. Operation Procedure

9.1 Connection and Settings

- 1) Confirm that the probe is sterilized.

⟨CAUTION⟩

Prior to each use, ensure that the probe is cleaned and sterilized in accordance with the procedure stated in "7.2 Reprocessing Procedure".

- 2) It is recommended to use a disposable probe cover for preventing a patient from infection and the probe cover should be allergy free material to avoid allergic reaction.

⟨WARNING⟩

Some Latex material may create allergic reaction.
See "2. General caution" for more detail.

- 3) Connect the probe to the ultrasound diagnostic scanner and operate the scanner and adjust the image according to the instructions given in the operation manual for the ultrasound diagnostic scanner.

⟨WARNING⟩

Set the ultrasound diagnostic scanner to "FREEZE ON" mode when replacing the probe.

- 4) Put proper quantity of sterilized acoustic jelly on the probe head as a couplant. (See Fig.8.)

Sterilized acoustic jelly

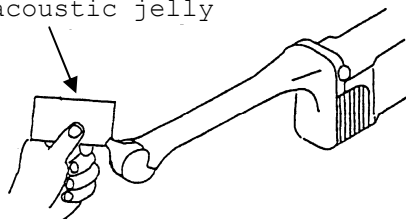

Fig.8

- 5) Put a probe cover on the probe and draw the probe cover until the end of the probe shaft. To avoid air bubbles, be careful to press the probe cover gently against probe head and to keep jelly on the probe head. If air bubbles appear on the probe head, remove air bubbles by pushing jelly with finger. (See Fig.9 and Fig.10.)

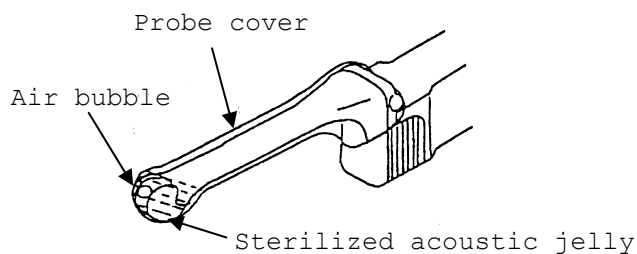

Fig.9

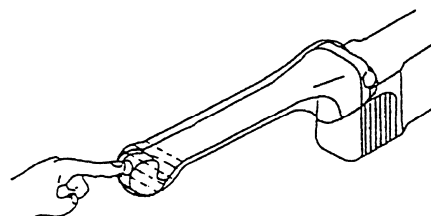

Fig.10

- 6) Fix jelly on the top of the probe with sterile adhesive tape. (See Fig.11.)

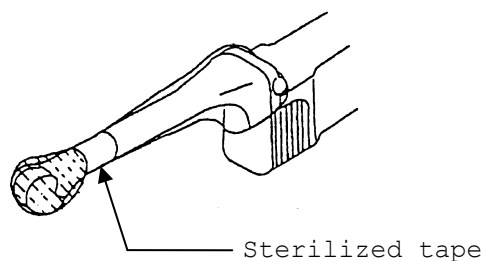

Fig.11

- 7) Insert the probe gently and adjust the probe's position for a clear view of the desired image. By turning or tilting of the probe, a "turn around" imaging is possible. If get an insufficient imaging, use sterile saline solution. The solution is better than the above-mentioned method to contact between probe and organ.
- 8) After using the probe, clean and disinfect or sterilize the probe immediately.
- 9) Store the probe in the environment indicated in "10. Maintenance and Safety Inspection".

9.2 Use of Puncture Adapter (EZU-PA3V)

The process of attaching the Puncture Adapter (EZU-PA3V) to the probe is as follows. If the Puncture Adapter shall be used, not to destroy the probe cover. During open or minimal invasive surgery, use the protection sleeve (Refer to 12.Supplier's List.) to cover probe and cable.

- 1) Attach a sterile probe cover to the probe. (See "9.1 Connection and Settings")
- 2) Put the picks of the Puncture Adapter to the grooves on the tip of the probe. (See Fig.12.)

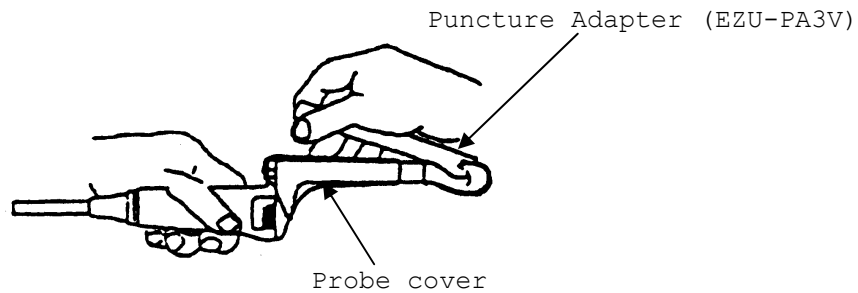

Fig.12

- 3) Push the other end of the Puncture Adapter until fix the dents of the Puncture Adapter to the projection on the probe. (See Fig.13.)

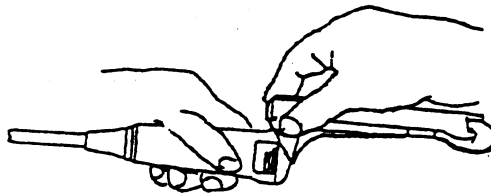

Fig.13

9.3 Display of Needle Guide Line

When puncture is to be conducted, the needle guideline can be displayed by dot marks. Operation procedure for displaying the needle guideline on the ultrasound diagnostic scanner must be referred to the part of "Needle guide line" in the manual of the connected the ultrasound diagnostic scanner.

NOTE: The needle guide line will be displayed to provide a visual guide to the direction of the puncture needle pathway. Be sure to check the actual location of the needle on the ultrasound image when performing the puncture operation.

〈CAUTION〉

The needle guide line can be displayed with this probe; however, some image display may not be appropriate for puncture procedure according to the location of observation field-of-view. Use observation field-of-view that is appropriately according to the location of puncture.

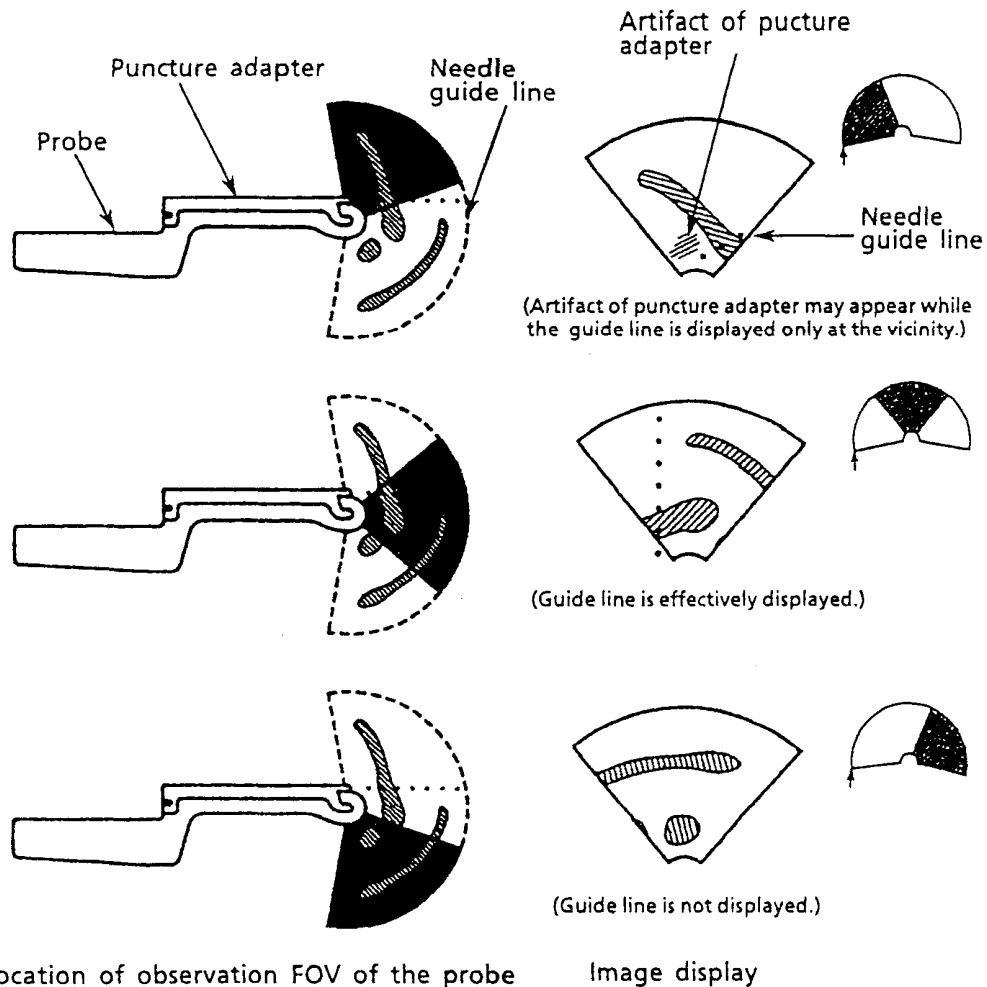

9.4 Diagnosis

Place the probe on the examination site and adjust the probe's position for a clear view of the desired image.

9.5 Care after use

Perform the reprocessing procedure in accordance with the procedure stated in "7.2 Reprocessing Procedure" every time immediately after completing the ultrasound examination.

10. Maintenance and Safety Inspection

10.1 Probe Care

Use gauze soaked in water or in ethyl alcohol to clean the dirt on the surface of the probe.

〈CAUTION〉

- (1) Do not attempt to scrape away caked dust on the probe with a hard cloth or knife.
- (2) Do not allow liquid to contact/enter the probe connector, as the probe connector is not waterproof.
- (3) Do not use Ethyl alcohol other than cleaning. Ethyl alcohol is not effective as a sterilant/disinfectant.

10.2 Daily Inspection

- (1) Visually inspect the surface of the probe head, the housing, and the cable for any crack, scratch or denaturalization. If you find damage, do not use the probe, and immediately contact our service personnel.
- (2) Visually inspect the ultrasound image for abnormality or major change from initial state. If you find abnormality or major change, do not use the probe, and immediately contact our service personnel.

11. Specifications

Type	: C41V Probe
Acoustic working	
Frequency	: 6.5MHz
Technology	: Convex Array Probe
Dimensions	: See Fig.14.
Weight	: Approx. 0.60kg (Including cable and connector)
Probe materials	: Biocompatible allergy free components
Applicable systems	: Depending on production and upgrade status for detailed information, contact a service support.
Cleaning	: Applicable detergents are listed in the supplier's list
Chemical Sterilization	: Applicable chemical sterilants are listed in the supplier's list
Sterilization	: ETO gas sterilization Plasma sterilization
Operating conditions:	
Ambient temperature:	+10 - +35°C
Contact surface temperature: (Temperature of examinee)	max. 42°C
Relative humidity:	30 - 85% (subject to no condensation)
Storage conditions:	
Temperature:	-10 - +55°C
Relative humidity:	10 - 95% (subject to no condensation)

12. Supplier's List

The products listed bellow are seriously tested and approved for use with the Convex array probe C41V.

Product name	manufacturer	purpose
Enzol [®]	Johnson & Johnson	Enzymatic detergent
Cidex [®]	Johnson & Johnson	Sterilant
Cidex Plus [®]	Johnson & Johnson	Sterilant
Transducer covers	CIVCO Medical	Covers
Sterile protection product	International Medical	Covers

13. Disposal of the probe

Recycle or dispose of equipment properly in compliance with your organizational rules and your local laws.

CAUTION

Before disposing of the equipment, disinfect or take other infection-prevention measures. Disposal of the equipment without taking the proper preventative measures can lead to infection.

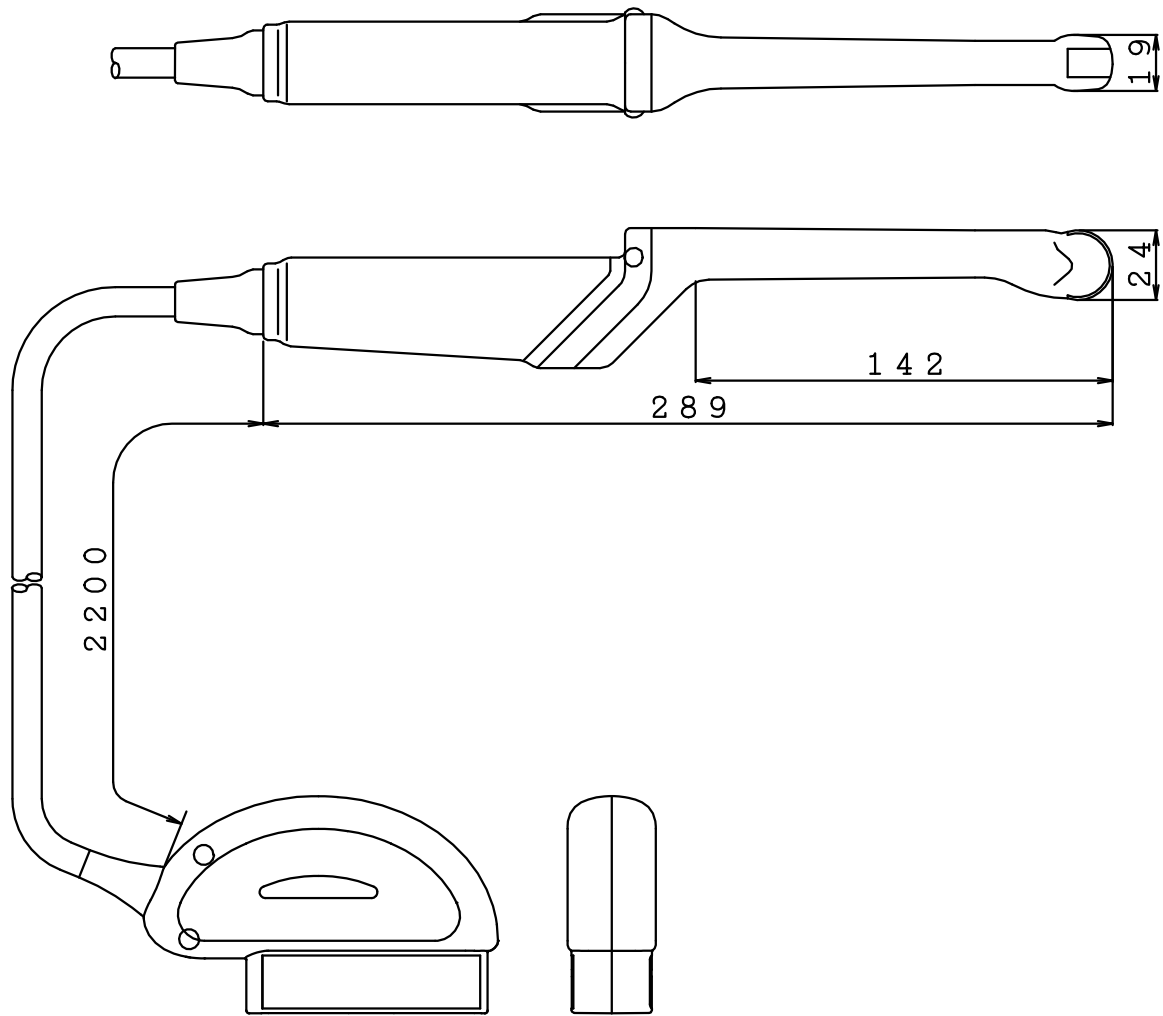

Unit: mm

Fig.14 External view of C41V Probe

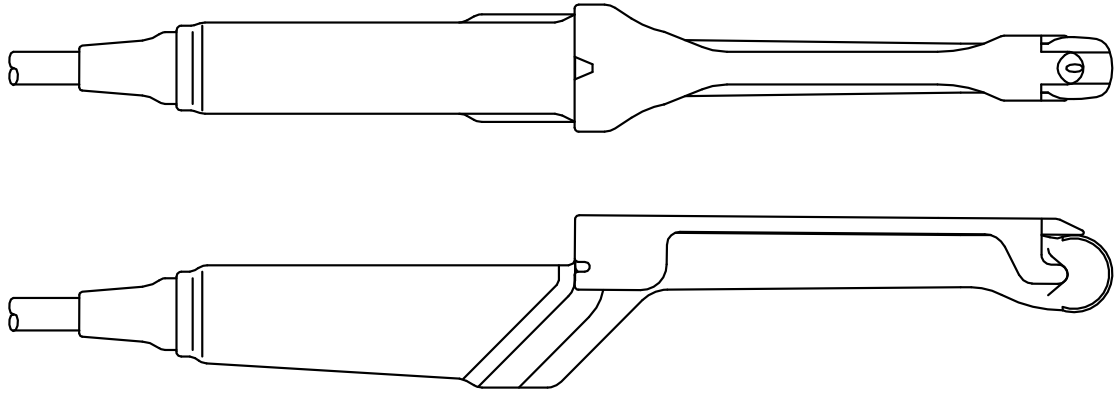

Fig.15 External view of C41V Probe with
Puncture Adapter (EZU-PA3V)

Manufacturer

Hitachi, Ltd.

2-16-1, Higashi-Ueno, Taito-ku, Tokyo, 110-0015, Japan

Contact

+81-3-6284-3668

<http://www.hitachi.com/businesses/healthcare/index.html>

Representative

Hitachi Aloka Medical America, Inc.

10 Fairfield Boulevard, Wallingford, CT 06492 U.S.A.